

HEAVY DUTY DIAL INDICATOR STAND

Unit: mm

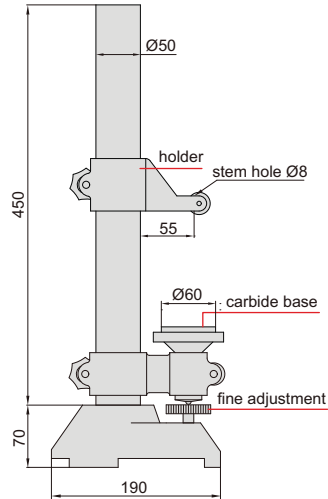

- Vertical travel of holder: 300mm
- Fine adjustment range: 5mm
- Carbide base
- Supplied with dust cover
- Optional accessory:
holder with stem hole $\text{Ø}28$ (code **6869-D28**)



6869-300

Code	Applicable holding stem	Base
6869-300	$\text{Ø}8\text{mm}$	plain, flatness $1\mu\text{m}$, carbide